

**Use:**  
For water and neutral liquids to maximum 160°F.

**Tests:**  
Hydraulic test to AWWA C503:  
Shell Test: 700 PSI

**Options:**  
Break Flange  
Hydrant Check Valve (FlowGuard II ® )

**Approvals:**  
UL Listed, FM approved  
at 250 PSI rated working  
pressure.



**Standard Materials:**

Nozzle Section	Ductile iron ASTM A536
Caps, Dummy Nuts	Cast iron ASTM A126 class B
Stems, Nozzles, Stem Nuts Thrust Nuts,	Bronze
Valve Discs	Bronze encapsulated with Nitrile Rubber
O-rings,	NBR
Cap Gaskets	Neoprene rubber
Nozzle Retainer Screws Thrust Collars	Stainless Steel
Cap Chains	Zinc Plated Steel
Coating	Electrostatically applied fusion-bonded epoxy-resin

Note: Nozzles, Stem Nuts and Stem Seals field replaceable

Pumper Nozzles interchangeable from 4" to 4½"

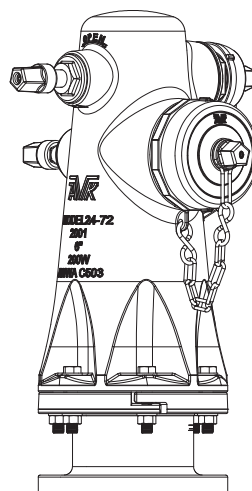

Series 2472  
1 Pumper, 1 Hose Outlet \*

\* Shown with optional Breakable Flange Assemblies  
Note: All configurations supplied with 6 - 3/4" holes at 9 3/8" pitch diameter.  
Breakable Flange Assemblies with 6" ANSI Standard 8 hole configuration are available as an option.



**Component List:**

19. Hose Nozzle Cap	109. Outer Stem Nut O-Ring	121. 4" - 4.5" Valve Carrier	135. 2.5" Thrust Nut
24. Chain Set	110. Stem Nut	122. Nozzle Section Bolt	136. 2.5" Thrust Collar
28. Pumper Cap	111. Inner Stem Nut O-Ring	123. Wet Barrel Flange O-Ring	137. 4.5" Valve Disc
31. Nozzle Section Washer	112. Dummy Nut	124. Break Ring	138. 4.5" Valve Stem
101. Nozzle Section	113. Dummy Nut Retaining Bolt	125. Nozzle Section Nut	139. 4.5" Thrust Nut
102. 2.5" Valve Stem	114. Retaining Screw	127. Wet Barrel Flange Section	140. 4.5" Thrust Collar
103. 2.5" Valve Carrier	115. Hose Nozzle Cap Gasket	128. Threaded Hose Nozzle O-ring	141. 4.5" Thrust Nut O-ring
104. Valve Carrier O-Ring	116. Hose Nozzle	129. Threaded Hose Nozzle	142. 2.5" Thrust Nut O-Ring
105. 2.5" Valve Disc	117. 4" - 4.5" Valve Stem	131. Threaded Pumper Nozzle O-ring	
106. 2.5" Valve Retainer	118. 4" - 4.5" Valve Disc	132. Threaded Pumper Nozzle	
107. Slotted Nut	119. 4" - 4.5" Valve Retainer	133. 2.5" Valve Disc	
108. Cotter Pin	120. Pumper Cap Gasket	134. 2.5" Valve Stem	

Top may be tapped for 2.5" auxiliary valve

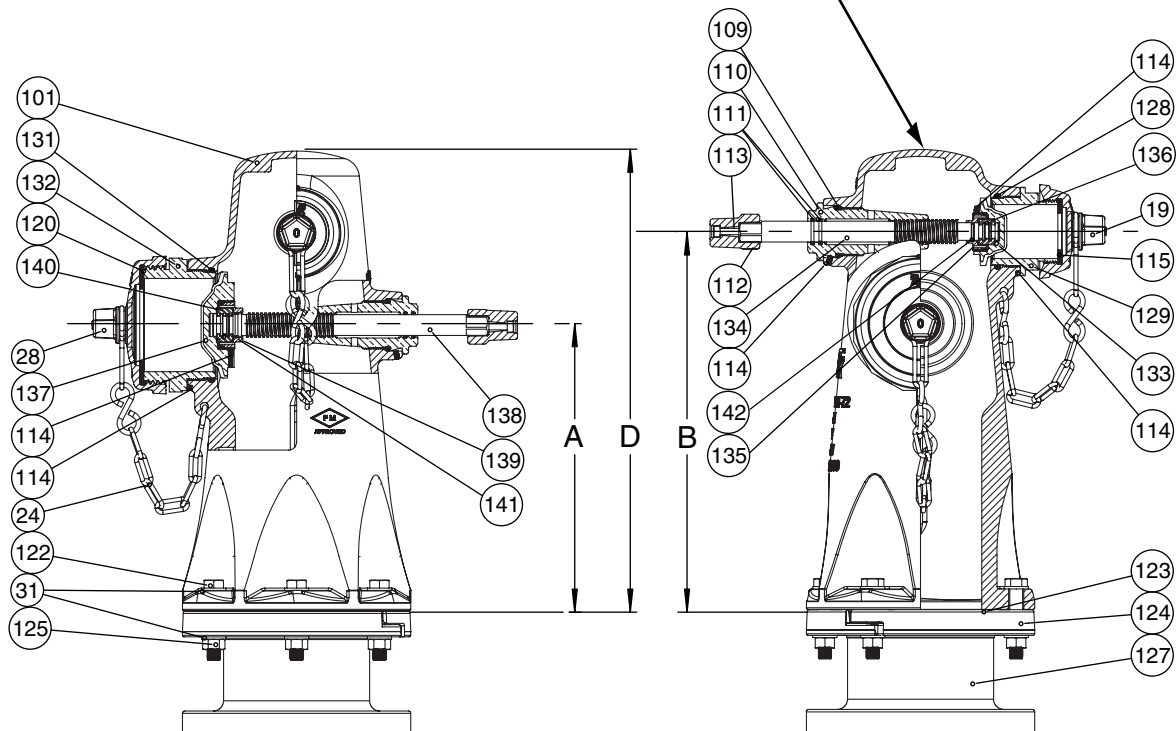

Ref No.	Outlets	A	B	D	Weights (lbs)
24-150-72	1x2.5", 1x4.5"	14"	18.50"	22.50"	82

With optional factory assembled breakable unit, add 42 lbs. to shipping weight.